

Q22HD 系列流体气控制阀

Q22HD Series Fluid Air Control Valve

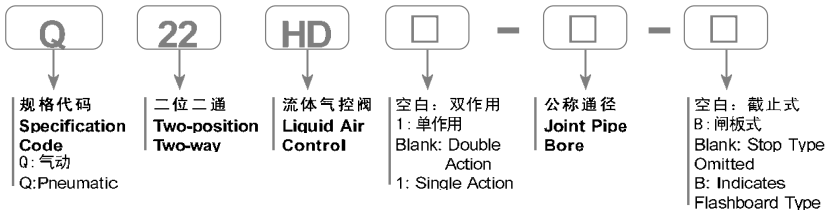

订购码 | Ordering Code



图形符 Graphic Symbol

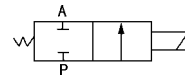

规格 | Specification

型号 Model	Q22HD-15	Q22HD-20	Q22HD-25	Q22HD-35	Q22HD-40	Q22HD-50
公称口径 Bore	15	20	25	40		15
接管螺纹 Joint Pipe Bore	G1/2"	G3/4"	G1"	G1 1/4"		G1/2"
工作介质 Working Medium	空气、水、油、液化气、轻动粘度液体 Air, Water, Oil, Gas, Free-running viscosity liquid					
工作压力 Working pressure	0.2~0.6MPa					
介质和环境温度 Temperature of Medium & Condition	5~50℃					
流量系数 KV 值 Flow Coefficient KV Value	4	5	10	25		40

外形尺寸 | Overall Dimension

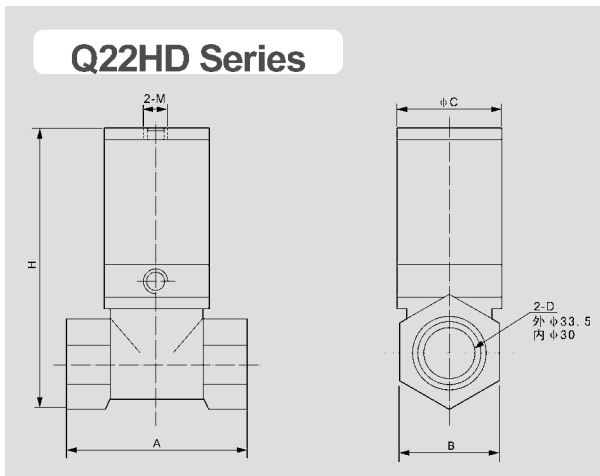

型号 Model	A	B	C	D	H	M
Q22HD-15	46	26	φ 30	G1/2"	96	G1/8"
Q22HD-20	54	32	φ 37	G3/4"	107	G1/8"
Q22HD-25	66	34	φ 37	G1"	118	G1/8"
Q22HD-35	80	53	φ 65	G1 1/4"	162	G1/8"
Q22HD-40	80	53.6	φ 65	G1 1/2"	162	G1/8"
Q22HD-50	105	66	φ 78	G2"	180	G1/4"